



AFTER COOLERS & SEPARATORS



Water-cooled After-Cooler



Liquid and Cyclone Separators



Air-cooled After-Cooler



Nortec After Coolers & Separators

AIR COOLED AFTER COOLERS

Nortec Aftercoolers offer an economical way of reducing the moisture content in the hot compressed air exiting the compressor. The moisture in the compressed air stream can be decreased by nearly 60% thereby reducing the load on the dryer (irrespective of whether it's a refrigerated or a desiccant dryer). Using a relatively smaller dryer and accessories is a direct saving of initial investment and associated periodic maintenance costs. The air-cooled after coolers can cool the compressed air temperature to about 5 - 20 Deg F of the ambient air temperature.

Features

- ◆ Advanced technology design maximizes the heat transfer with minimum pressure drop
- ◆ Up to 60% smaller than conventional fin and tube designs
- ◆ Rugged bar & plate designs
- ◆ Compact durable aluminum plate core design saves energy usage
- ◆ Reduced air side fouling
- ◆ Horizontal airflow standard with optional vertical airflow
- ◆ Corrosion resistance construction. TEFC fan for outdoor applications

Specifications

RATINGS:

Maximum Working Pressure 250 PSI

Maximum Working Temperature 250° F

CONSTRUCTION MATERIAL:

Cooler Aluminum

Shroud Powder Painted Steel

Fan Guard Zinc Plated Steel

Fan Blade Polypropylene Blades Aluminum Hub

Mounting Brackets Powder Painted Steel

Air Cooled After Cooler Specifications

Model Size	A	B	C (Approx.)	E	F	G	H (NPT)	I	J	K	L	M	N	Weight in Lbs.	
														Approx NET.	Shipping
130-AC	12.64	15.94	14.72	10.86	2.52	0.75	1.18	1.00	14.65	3.94	3.50	8.19	M8x10 Bolt	30	40
225-AC	16.30	19.88	15.59	14.53	2.52	0.75	1.77	1.50	18.66	3.94	3.50	8.19	M8x10 Bolt	50	60
450-AC	21.00	26.38	17.75	18.81	3.15	1.00	1.77	2.00	25.19	4.92	4.53	10.98	M10x20 Bolt	95	137
800-AC	23.19	30.31	18.74	21.02	3.15	1.00	1.77	2.00	29.13	4.92	4.53	10.98	M10x20 Bolt	125	163
1400-AC	27.72	37.00	22.60	25.23	4.33	1.85	1.77	2.50	37.80	5.91	7.87	16.00	M12x20 Bolt	195	240
2000-AC	35.90	40.94	24.76	30.83	4.33	1.85	1.77	3.00	37.80	5.91	7.87	16.00	M12x20 Bolt	296	350
3000-AC	37.44	42.91	29.84	30.55	10.91	2.08	1.77	4.00	43.62	5.39	7.87	15.47	M12x20 Bolt	320	380
3500-AC	44.25	48.82	30.28	34.25	11.57	1.57	1.77	4.00	49.29	5.39	7.87	15.47	M12x20 Bolt	440	505
4500-AC	57.87	52.76	33.82	43.98	17.56	3.35	2.00	4.00	50.55	7.80	10.00	20.00	3/4x1-1/2 Bolt	550	645

SAE 4-Bolt Flanges may be converted to NPT by adding "-AD" to the end of the model code

*Dimensions in inches, *Air connections may be reversed

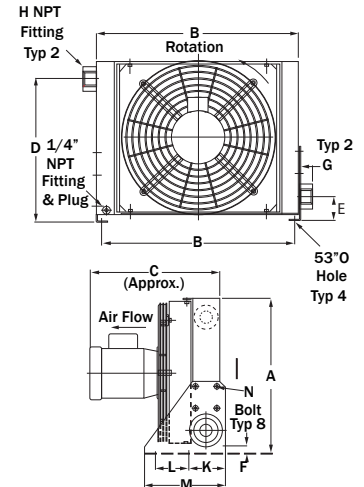

Electric Motor Specifications

Model Size	HP RPM	Motor Frame	Single Phase			Three Phase-Voltage		Full Load Amps 230 V
			Voltage	HZ	Full Load Amps 230 V	60 HZ	50 HZ	
130-AC	1/3 3450	IEC 63	115/230	60	2.6	208-230/460	200-220/380-440	1.2
225-AC	1/2 3450	IEC 71	115/230	60	3.4	208-230/460	200-220/380-440	1.2
450-AC	1/2 1725	NEMA 56C	115-230/460	60	4.4	208-230/460	190-200/208-220 380-400/416-440	2.0
800-AC	1 1725	NEMA 56C	115-230/460	60	6.4	208-230/460	190-200/208-220 380-400/416-440	3.4
1400-AC	2 1725	NEMA 56C	115/230	60	10	208-230/460	190-200/208-220 380-400/416-440	6.2
2000-AC	5 1725	NEMA 184TC	230	60	23	208-230/460	190-200/208 380-400/416	13.4
3000-AC	7.5 1725	NEMA 213TC	Consult Factory			208-230/460	190-200/208 380-400/416	19.2
3500-AC	7.5 1725	NEMA 213TC				208-230/460	190-200/208 380-400/416	19.2
4500-AC	10 1725	NEMA 213TC				208-230/460	190-200/208 380-400/416	25.0

*Electric motors are TEFC and are not thermally protected.
*Motor RPM is reduced by 1/6 for 50 Hz service.

*Actual rating may vary with motor brand. Check motor nameplate for actual rating.

Nortec After Coolers & Separators

(Optional) Air Motor Specifications

Model Number	Air Pressure To Motor (PSI)	Motor Air Consumption (CFM)	Air Motor Connection Size	Fan RPM
130-AC	30	10	1/4" NPT	3450
225-AC	60	17	1/4" NPT	3450
450-AC	40	25	1/4" NPT	1725
800-AC	40	25	1/4" NPT	1725
1400-AC	50	70	1/2" NPT	1725
2000-AC	60	150	1 1/4" NPT	1725
3000-AC	80	200	1 1/4" NPT	1725
3500-AC	80	200	1 1/4" NPT	1725
4500-AC	100	240	1 1/4" NPT	1725



*DO NOT EXCEED fan RPM listed above.
*Mufflers are included with all motors.

*Air pressure to motor MUST be regulated and lubricated.

WATER COOLED AFTER COOLERS



Nortec Water-cooled After-Cooler provide an affordable way to reduce the moisture content in the compressed air stream. Installing correctly sized water cooled Aftercooler and liquid separator after the compressor, can reduce nearly 65~70%

of the moisture from the hot saturated compressed air. The capital cost of a water-cooled after cooler and a corresponding separator can be recovered by the saving in equipment downtime and maintenance costs.

Features

- ◆ Shell and tube reliability. Counter-flow design provides maximum heat transfer
- ◆ Maintenance friendly - Cleanable air side and drains on the shell side
- ◆ All brass shell and tube assemblies reduces corrosion
- ◆ Forged brass end hubs (optional stainless steel)
- ◆ Copper tubes (optional copper nickel, stainless steel)
- ◆ All stainless construction (optional)
- ◆ Cast iron end bonnets (optional brass & stainless steel)
- ◆ Compact design – can be mounted horizontal or vertical

Specifications

Model	Capacity @ 100 PSIG		Max.W.P PSIG	Air Connections	Water Connections	Dimensions L x Diameter (inches)	Recommended Options	
	2 STG	Rotary					Moisture Separator	Drain Valve
60-WAF	40	60	200	1 1/2" NPT	1/2" NPT	28 x 4	65-SEP	BTS-25-1
125-WAF	80	125	200	1 1/2" NPT	1/2" NPT	20 x 5	125-SEP	BTS-25-1
225-WAF	150	225	200	1 1/2" NPT	1/2" NPT	36 x 5	200-SEP	BTS-25-1
450-WAF	310	450	200	2 1/2" NPT	1" NPT	36 x 6	450-SEP	BTS-50-1
700-WAF	440	700	200	3" NPT	2" NPT	45 x 6	600-SEP	BTS-50-1
1000-WAF	640	1000	200	3" NPT	2" NPT	45 x 6	900-SEP	BTS-50-1
1700-WAF	1250	1700	200	3" NPT	2" NPT	63 x 6	1500-SEP	BTS-50-1
2500-WAF	1600	2500	200	3" NPT	2" NPT	72 x 6	2500-SEP	BTS-75-1
3200-WAF	2100	3200	150	4" NPT	3" NPT	90 x 8	3500-SEP	BTS-75-1
3500-WAF	2800	3500	150	4" FLG	3" NPT	80 x 12	3500-SEP	BTS-75-1

LOW AND HIGH PRESSURE CYCLONE SEPARATORS (LS & DF SERIES)

Nortec separators use the proven method of centrifugal force to separate the entrained liquid from the compressed air. The trapped water accumulates at the bottom and is periodically removed by an electronic timer drain valve. With proper sizing and, these separators can eliminate 99% of all entrained liquids and particles that are 10 microns and larger in size.

Features

- ◆ Electronic Timer Drain Valve (Manual available as an option)
- ◆ Removes over 99% of the moisture
- ◆ LS Separator are made from Cast Aluminum, DF Series – Stainless/Carbon Steel
- ◆ DF Separators are manufactured in accordance to ASME Section VIII, Div1 specifications
- ◆ Rated for 230 PSIG
- ◆ Compact and lightweight - can be supported by just the piping
- ◆ Available capacities range from 5 to 10,000 SCFM

Nortec After Coolers & Separators

Liquid Separators LS Series

Specifications

Model Number	Flow rate (SCFM)	Inlet/Outlet (Inches)	Max. Pressure (PSIG)	Weight (Lbs)	Drain (Inches)
35-LS	35	3/8 NPT	230	1.7	1/4
50-LS	50	1/2 NPT	230	1.7	1/4
75-LS	75	3/4 NPT	230	2.0	1/4
125-LS	125	1 NPT	230	5.0	1/2
200-LS	200	1 1/2 NPT	230	5.8	1/2
300-LS	300	1 1/2 NPT	230	6.4	1/2
450-LS	450	1 1/2 NPT	230	8.4	1/2
600-LS	600	2 NPT	230	16.5	1/2
900-LS	900	2 1/2 NPT	230	22.0	1/2
1500-LS	1500	3 NPT	230	55.0	1/2



Cyclone Separators DF Series

Specifications

Model Number	Pipe Size (Inches)	Capacity SCFM	Dimensions in Inches						Weight	
			A	B	C	Dia	G	Drain	150 PSIG @ 450° F	500 PSIG @ 650° F
250-DF	1	250	10 1/2	10 1/2	16	5 9/16		1	33	35
300-DF	1 1/4	300	10 1/2	10 1/2	16	5 9/16		1	35	37
400-DF	1 1/2	400	11 1/2	12 1/2	19	6 5/8		1	50	56
750-DF	2	750	11 1/2	12 1/2	19	6 5/8		1	55	59
1200-DF	2 1/2	1200	16	15	22	8 5/8		1	100	110
1500-DF	3	1500	18	18	26	10 3/4	5 3/4	1	140	150
2500-DF	4	2500	20	22	31	12 3/4	5 3/4	1 1/2	195	220
3500-DF	5	3500	22	26	36	14	7 7/8	1 1/2	230	290
5000-DF	6	5000	24	30	41	16	7 7/8	1 1/2	350	380
7500-DF	8	7500	28	37	50	18	7 7/8	2	475	610



NORTEC CORPORATION

Compressed Air, Gas & Fluid Technologies

1713 Henry G. Lane, Maryville TN 37801

Tel: 865-980-6100 Fax: 865-980-6190

www.nbdry.com



Water Saver and Pumping Stations



High Capacity Dryers



Fluid Chillers



Refrigerated Dryers



Desiccant Dryers
Heatless & Heated